

River Water Quality Zoning: A Case Study of Karoon and Dez River System

***M Karamouz¹, N Mahjouri², R Kerachian³**

¹*School of Civil and Environmental Engineering, Amirkabir University, Iran*

²*Faculty of Environmental Engineering, University of Tehran, Iran*

³*Dept. of Civil Engineering, University of Tehran, Iran*

ABSTRACT

Karoon-Dez River basin, with an area of 67000 square kilometers, is located in southern part of Iran. This river system supplies the water demands of 16 cities, several villages, thousands hectares of agricultural lands, and several hydropower plants. The increasing water demands at the project development stage including agricultural networks, fish hatchery projects, and inter-basin water transfers, have caused a gloomy future for water quality of the Karoon and Dez Rivers. A good part of used agricultural water, which is about 8040 million cubic meters, is returned to the rivers through agricultural drainage systems or as non-point, return flows. River water quality zoning could provide essential information for developing river water quality management policies. In this paper, a methodology is presented for this purpose using methods of *c*-mean crisp classification and a fuzzy clustering scheme. The efficiency of these clustering methods was evaluated using water quality data gathered from the monitoring sampling points along Karoon and Dez Rivers. The results show that the proposed methodology can provide valuable information to support decision-making and to help river water quality management in the region.

Keywords: *Fuzzy Clustering, Data classification, Water quality zoning, River systems, Karoon, Dez*

INTRODUCTION

There are many similarities between certain phenomena in the nature. Quantitatively interpreting these similarities can make it possible to categorize the components of a system into different classes based on a pre-defined criterion. One of the main applications of the “clustering methods” is zoning the river systems based on various water quality variables. River quality zoning is important in determining the critical zones, optimal locations of the monitoring stations and water intakes as well as proposing

water quality control projects.

Horton (1965) proposed the first Water Quality Index (WQI). The critical issue in water quality zoning is to construct WQI in a simple way so that the correct information can be extracted from measurements in order to illustrate the special and temporal variations (Ott, 1980). Simple weighing method, which is usually used for water quality zoning, depends on expert judgments and therefore has been greatly influenced by human subjectively, even though all parameters are carefully measured. In addition, technical interpretation of WQIs is usually difficult and indexing methods have some weaknesses in explaining a complicated situation. In

***Corresponding author:** *E-mail: karamouz@aut.ac.ir
Tel: +98 21 664543014, Fax: +98 21 66414213,*

some cases, an expert should check the concentration of all of the water quality variables for water quality explanation and it significantly reduces the value of the index methods.

Most of the traditional tools for formal modeling and computing are crisp, deterministic and precise in characteristics. Zadeh (1965, 1973) stated that real situations are very often uncertain or vague in a number of ways; he called this vagueness "fuzziness" and proposed the Fuzzy Sets Theory.

After that, many theoretical developments in fuzzy logic took place. Now, fuzzy logic affects many disciplines in different fields of study. There is an underlying structure to be understood. We often seek to find structure in the data obtained from observation such as water quality data provided by a monitoring system. Finding the data structure is the essence of classification. In data classification, also termed clustering, the most important issue is deciding what criteria to classify against it. In water quality zoning, deviation from water quality standard is usually considered as the clustering criteria.

Classical (crisp) clustering algorithms generate different clusters so that each object is assigned to exactly one cluster. However, in many cases, objects cannot adequately be assigned to strictly one cluster because they are located between clusters. In such a case, fuzzy clustering method may provide clusters that are more realistic by assigning overlapping membership functions. Kung et al. (1992) proposed a water quality index for water quality assessment and showed that fuzzy clustering analysis might be used as a complement or an alternative to common quantitative methods in water quality assessment, especially when WQI scores are close to the thresholds between normal and abnormal condition. In this paper, the main characteristics of crisp and fuzzy clustering methods and their suitability for river water quality zoning are presented and the efficiency of these methods are evaluated using water quality data of Karoon-Dez River system.

METHODOLOGY

In this paper, the efficiency of the two well-known classification methods, namely hard c-mean crisp classification and fuzzy clustering are evaluated.

Hard c-means (HCM)

HCM is used to classify data in a crisp sense. In this method, each data point will be assigned to one, and only one, data cluster. A family of sets $\{A_i, i = 1, 2, \dots, c\}$ as a hard c -partition of set X should be defined. The following constraints are applied to these partitions:

$$A_1 \cup A_2 \dots \cup A_c = X \quad (1)$$

$$A_i \cap A_j = \phi \quad \forall i \neq j \quad (2)$$

$$\phi \subset A_i \subset X \quad \forall i \quad (3)$$

$$2 \leq c < n \quad (4)$$

Where $X = \{x_1, x_2, x_3, \dots, x_n\}$ is a finite set, comprised of the of data samples, and c is the number of partitions or clusters, in which the data will be classified. Where $c = n$, classes just places each data sample into its own class, and $c = 1$ places all data samples into the same class; neither case requires any effort in classification and both are intrinsically uninteresting. Equation 1 expresses the fact that the set of all classes exhaust the universe of data samples. Equation 2 indicates that none of the classes overlaps in the sense that a data sample can belong to more than one class. Equation 3 simply expresses that a class cannot be empty and it cannot contain all the data samples.

Within all the possible c -partitions for n data samples, the most reasonable c partition should be selected. A within-class sum of squared errors approach using Euclidean norm to characterize distance, is used in c -mean clustering. In this approach, Euclidean distance is measured between the k^{th} data sample x_k and i^{th} cluster center \tilde{v}_i by the following expression (Ross, 1997):

$$d_{ik} = \|x_k - \tilde{v}_i\| = \left[\sum_{j=1}^m (x_{kj} - v_{ij})^2 \right]^{0.5} \quad (5)$$

Since each data sample requires m coordinates to describe its location in m dimensional space, each cluster center also requires m coordinates to describe its location in this same place. Therefore, the i^{th} cluster center is a vector of length m as:

$$\tilde{v}_i = \{v_{i1}, v_{i2}, \dots, v_{im}\} \quad (6)$$

Where the j^{th} coordinate is calculated by:

$$v_{ij} = \frac{\sum_{k=1}^n \chi_{ik} \cdot x_{kj}}{\sum_{k=1}^n \chi_{ik}} \quad (7)$$

$$\chi_{ij} = \begin{cases} 1 & x_j \in A_i \\ 0 & x_j \notin A_i \end{cases} \quad (8)$$

The optimum partitions that are selected produce the minimum value for the following objective function.

$$\text{Min } z = \sum_{k=1}^n \sum_{i=1}^c \chi_{ik} (d_{ik})^2 \quad (9)$$

Fuzzy clustering using equivalence relation. In fuzzy clustering, to classify data points using fuzzy relations, we need to find the associated fuzzy equivalence relation. A fuzzy relation, on a single set X is also a relation from X to X . It is a fuzzy equivalence relation if all of the following three properties for matrix relation can be applied:

$$\text{Reflexivity} \quad \mu_R(x_i, x_i) = 1 \quad (10)$$

$$\text{Symmetry} \quad \mu_R(x_i, x_j) = \mu_R(x_j, x_i) \quad (11)$$

Transitivity

$$\mu_R(x_i, x_j) = \lambda_1 \text{ and } \mu_R(x_j, x_k) = \lambda_2 \rightarrow \mu_R(x_i, x_k) = \lambda \text{ where } \lambda \geq \min[\lambda_1, \lambda_2] \quad (12)$$

In which, $\mu_R(x_i, x_j)$ is the membership function of the fuzzy relation R , which shows the similarity of, x_i and x_j . When there are several criteria in evaluating the similarity of some elements, fuzzy relation can be presented by a similarity matrix. Many investigators have proposed several similarity matrices. For example, Wang (1983) proposed the following similarity matrix:

$$r_{ij} = \left\{ \frac{\sum_{k=1}^p (x_{ik} \cdot x_{jk})}{\sum_{k=1}^p (x_{ik} \cdot x_{ik}) \cdot \sum_{k=1}^p (x_{jk} \cdot x_{jk})} + \frac{p}{\sum_{i=1}^p (x_{ik} \cdot x_{ik}) - \sum_{i=1}^p (x_{jk} \cdot x_{ik})} \right\} \quad i \neq j \quad (13)$$

$$r_{ij} = M \geq \text{Max}(r_{ij} \quad \forall i \neq j) \quad i \neq j \quad (14)$$

Where, r_{ij} is ij^{th} element of the similarity matrix, x_{ik} is the value of k^{th} criterion for element i , and p is equal to the number of criteria such as water quality indicators. According to this formula, the value of the diagonal of the new matrix should be greater than the greatest element of the matrix.

In most real cases, the fuzzy relation being established is not stabilized; it meets the reflexivity and symmetry requirements, but not the transitivity. Thus, the fuzzy relation has to

be transformed before it can become part of a clustering chart. This transformation can be done through a Max-Min self-multiply processing of fuzzy matrix that is:

$$r_{ij} = V(r_{ik} \wedge r_{jk}) \quad (15)$$

Where V is the maximum operator and \wedge is the minimum operator; r_{ij} represents the element of the i^{th} row and the j^{th} column in the similarity measure matrix R and can be defined as follows:

$$r_{ij} = \frac{\sum_{k=1}^m \min(x_{ik}, x_{jk})}{\sum_{k=1}^m \max(x_{ik}, x_{jk})} \quad i, j = 1, 2, \dots, n \quad (16)$$

After several steps, the fuzzy relation converges to R^* which is a stabilized relation (Wang, 1983):

$$R^* = R^k = R^{2k} \quad (17)$$

Where, R^k is the similarity matrix after K^{th} Max-Min self-multiplying process. In spite of non-fuzzy relations that their elements can be only 0 and 1, fuzzy relation elements can have the quantities between 0 and 1. For the data classification with the equivalence fuzzy relations, it is necessary to find the stabilized equivalence fuzzy relations. Then the data based on different λ cuts should be classified. For example, assuming that the matrix R is an stabilized equivalence fuzzy relation, applying the λ cuts 0.9, we have:

$$R = \begin{bmatrix} 1 & .8 & .4 & .5 & .8 \\ .8 & 1 & .4 & .5 & .9 \\ .4 & .4 & 1 & .4 & .4 \\ .5 & .5 & .4 & 1 & .5 \\ .8 & .9 & .4 & .5 & 1 \end{bmatrix} \quad R_{0.9} = \begin{bmatrix} 1 & 0 & 0 & 0 & 0 \\ 0 & 1 & 0 & 0 & 1 \\ 0 & 0 & 1 & 0 & 0 \\ 0 & 0 & 0 & 1 & 0 \\ 0 & 1 & 0 & 0 & 1 \end{bmatrix}$$

Based on different values of λ cuts, we can classify the data as illustrated in Table 1 and Fig 1.

The main five steps in river water quality zoning using fuzzy clustering analysis are as follows:

a) Selection the clustering criteria

In river water quality zoning, the clustering criteria are usually the concentration of indicator water quality variables. These indicator variables and therefore the water quality zoning, usually depend on the beneficial uses of the surface water.

b) Standardizing of the water quality data

The available data related to the concentration of water quality variables should be standardized to make them compatible. To standardize the concentration of the water quality pollutant such as *TDS*, the measured concentration is divided by the corresponding standard value. For some water quality variables such as *DO*, which a higher concentration shows a better water quality condition, the observed concentration is standardized by dividing the measured concentration by the related standard.

c) Determination of the similarity matrix

Equations 13 and 14 can be used to develop a similarity matrix. In these equations, n is the number of monitoring stations, x_{ik} is a standard concentration and p is equal to the number of indicator water quality variables.

d) Matrix Stabilizing

The similarity matrix should be stabilized using Max-Min self-multiplying process.

e) Determining the clusters

In this step, considering the objectives of water quality zoning, the clusters are determined based on different values of λ cuts.

The water quality zoning was applied to Karoon and Dez Rivers water quality data using the crisp and fuzzy clustering methods.

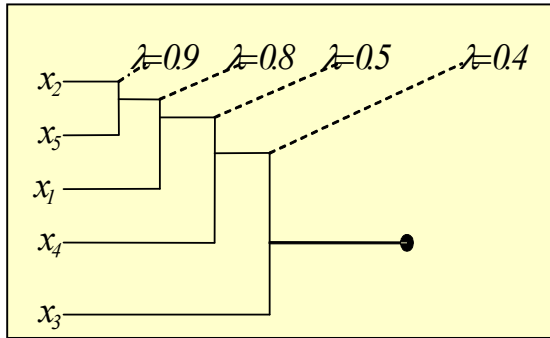

Fig. 1: Clustering diagram and the concept of λ cuts for fuzzy relation R

Table 1: Clustering of 5 points based on fuzzy relation R and on different quantities of λ cuts

Clustering results	λ
$\{x_1\}\{x_2\}\{x_3\}\{x_4\}\{x_5\}$	1
$\{x_1\}\{x_2, x_5\}\{x_3\}\{x_4\}$	0.9
$\{x_1, x_2, x_5\}\{x_3\}\{x_4\}$	0.8
$\{x_1, x_2, x_4, x_5\}\{x_3\}$	0.5
$\{x_1, x_2, x_3, x_4, x_5\}$	0.4

CASE STUDY

The Karoon-Dez River basin, with an area of 67000 square kilometers, is located in southern part of Iran. Karoon River water pollution due to increasing water withdrawals from and wastewater discharges into this river has endangered the aquatic life of the river. Furthermore, the drinking and in-stream water quality standards have been violated in many instances. Water pollution of Karoon River system can significantly affect the development of Khuzestan Province as one of the strategic provinces of the country with a high potential for agricultural and industrial development. A good part of used agricultural water is returned to the rivers by drainage and return flows. The return flows have a high concentration of fer-

tilizers, heavy metals, suspended and dissolved solids and pesticides, which violate from the national effluent standard. Agricultural and agro-industrial return flows, domestic wastewater of the cities and villages and industrial effluents are the main pollution point sources of the surface and groundwater resources in the Karoon and Dez River basins. Fig. 2 illustrates the location of the main agricultural, industrial and domestic pollution sources in the study area. Additionally, there are some diffused pollution sources, which are not so visible, but could also be significant. The Karoon-Dez river system supplies the water demands of 16 cities, several villages, thousands hectares of agricultural lands, and several hydropower plants. Increasing water demands at the development stage including agricultural networks, fish hatchery projects, and inter-basin water transfers, could result in a gloomy future for water quality of the Karoon and Dez Rivers. In such a system, water quality zoning is needed for better river water quality management.

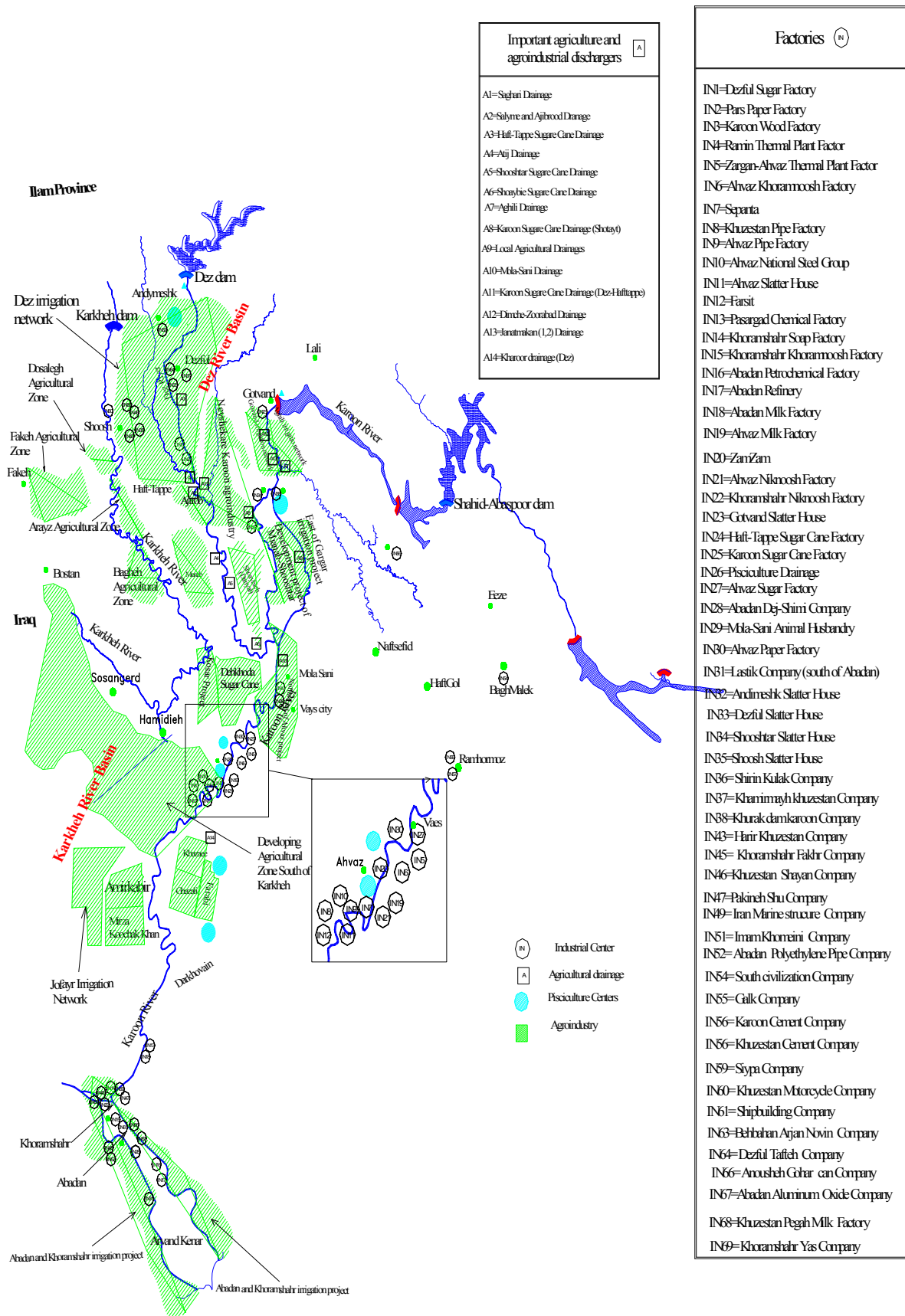

Fig. 2: The main components of the system in the Karoon-Dez River Basin

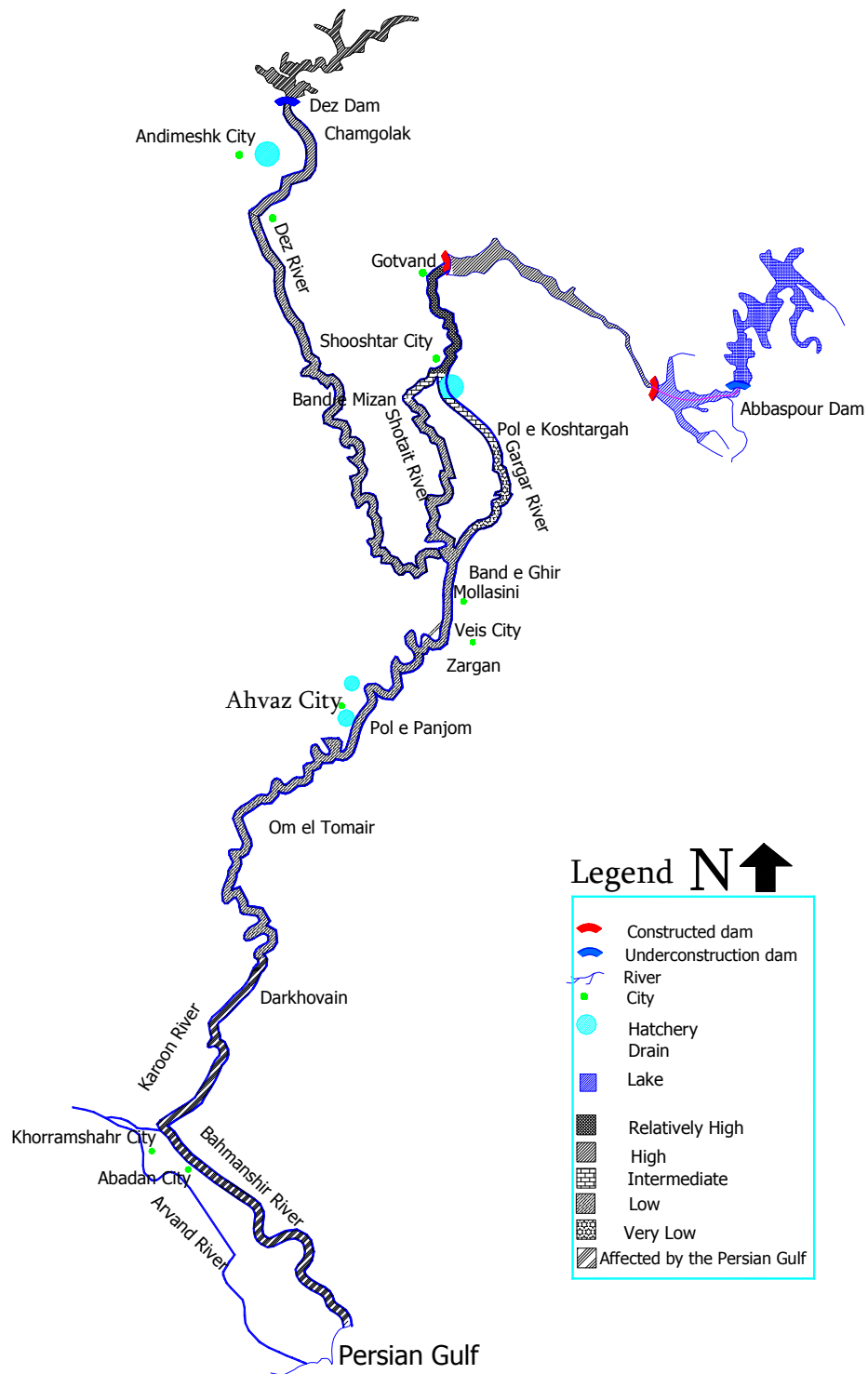

Fig. 3: River water quality zoning using fuzzy clustering method considering the river water quality standard ($\lambda = 12.5$)

RESULTS

Water quality data of the sampling points of Khuzestan Department of Environment and Khuzestan Water and Power Authority during the years of 1992-2001 are used. The data deficiencies are tackled using the correlation between water quality variables as well as engineering judgment.

Karoon Water Quality Zoning Using C-Mean Method as mentioned before, the first step in water quality zoning is the selection of clustering criteria, which are the concentrations of water quality variables. In this study, for classification based on river water quality, nine water quality variables of

$TDS, COD, BOD, SO_4^{2-}, NO_3, TSS, CL, DO$ and PO_4^{3-}

were considered. These variables have been partially deviated from the standards. Table 2 presents the selected water quality variables and the standard values for different water uses. Table 3 presents the location of different reaches in the study area and their water quality sampling points. The reaches downstream of Darkhovain, were not considered in this study because the quantitative and qualitative characteristics of the river were considerably affected by the backwater of the Persian Gulf and the order of magnitude of concentration of water quality variables in this zone is considerably different compared with the concentration in the other reaches. The results of the c-mean clustering method considering the river water quality standard, are presented in Table 4. As it is obvious in this table, the river water quality can be classified considering different number of classes. The results of Karoon-Dez River water quality zoning for 3 to 7 classes are presented in Table 4. This table shows the classification of the river water quality from less polluted reach (class 1) to the most polluted one (class 9). In all clustering, reach 7, which is located in downstream section of the Gargar River, is the most polluted reach considering

the selected water quality variables and the river water quality standard.

Karoon Water Quality Zoning Using Fuzzy Clustering Method The main steps of water quality zoning using fuzzy clustering method were presented in the methodology section. For calculating the similarity matrix elements, equations 13 and 14 were used. The number of the reaches related to the quality zoning is equal to 11. Therefore, the resulting matrix is an 11 by 11 matrix. The elements of the matrix should be stabilized using the Max-Min operator. Considering the concentrations of nine selected water quality variables, similar reaches based on the different values of λ cuts are determined and ranked from the less polluted to the most polluted zone. In the following sections, considering different water uses, the results of classification for each of the λ cuts are explained:

River water quality zoning considering river water quality and aquatic life Water quality variables used in this section and their corresponding standard described in the previous sections. The results of fuzzy clustering analysis are presented in Table 5. According to the table, for a small value of λ (less than 2.9), all of the reaches are located in a same class by increasing the λ value to 3.5; the reaches are classified into two classes. By increasing, the λ value to the values more than 6.5, the nine reaches that are located in downstream of Dez and Gotvand Dams, is located in different classes. As presented in Table 5, the reaches can be ranked from the less polluted to the most polluted for each value of λ .

Selecting a λ value equal to 12.5 classifies the reaches to five different classes. Reach seven (in Gargar branch of Karoon River near to the Gargar-Band e Ghir) that is located in a separated class, has the most critical water quality condition. The concentration of some water quality variables such as COD, BOD, TSS, CL and Hardness is usually more than the recommended standard in this reach. This critical

condition is mainly due to discharging agricultural return flow and wastewater of fish hatcheries, in the Gargar River.

The reaches between Band e Ghir and Om el Tomair that have a similar water quality condition are located in the same class. Mollasani drain, effluent of Ramin and Zargan power plants, wastewater of Ahvaz city and large industries, which are located in these reaches, are the main pollution sources of the polluted zone. As shown in Table 5, reach 1 located immediately in downstream of Dez dam reach has the best water quality condition and is located in a separated class. Although, reach 3 which is located immediately downstream of Gotvand dam has an acceptable water quality condition, the water quality in reaches 1 and 3 is partially different and these two reaches are located in different classes due to discharging Masjed Soleiman domestic wastewater and agricultural drains in the Gotvand region. Fig. 3 illustrates water quality zoning using fuzzy clustering method for a λ value equal to 12.5.

River water quality can also be classified considering drinking water uses. Eight water quality variables are selected to evaluate the river water quality for drinking uses. These water quality variables were *TDS*, *COD*, *BOD*, *SO₄*, *NO₃*, *TSS*, *Cl⁻* and Hardness. The results of fuzzy clustering analysis for drinking water uses are presented in Table 6.

River water quality zoning can also be conducted considering irrigation water uses. The selected water quality variables for evaluating Karoon and Dez River water quality for irrigation purposes are *SAR*, *TDS* and *Cl⁻*. The results of fuzzy clustering analysis in such a case are presented in Table 7.

Table 2: Selected indicator water quality variables for different uses and their recommended standards

Selected variable	River water quality standard (mg/lit)	Drink use standard (mg/lit)	Irrigation use standard (mg/lit)
<i>TDS</i>	1200	1000	1200
<i>DO</i>	>4	-	-
<i>SO₄</i>	250	250	-
<i>NO₃</i>	44	10	30
<i>Cl⁻</i>	200	200	200
<i>BOD</i>	10	3	-
<i>COD</i>	40	20	-
<i>PO₄</i>	0.7	-	-
<i>TSS</i>	0	0	-
Total Hardness	-	500	-
<i>SAR</i>	-	-	*

* The standard of SAR is different depending on the value of hydraulic conductivity. This variable hse not been considered in analysis

Table 3: Karoon-Dez River reaches selected for quality zoning

Reach Number	Location	Indicator Station	Reach Number	Location	Reach Name
1	Between Dez Dam and Dezful City	Dez-ChamGolak	7	Between Pol e Koshtargah and Band e Ghir	Gargar-Band e Ghir
2	Between Dezful City and Band e Ghir	Dez-Band e Ghir	8	Between Band e Ghir and Veis City	Karoon-Band eGhir
3	Between Gotvand Dam and Shooshtar City	Karoon-Gotvand Dam	9	Between Veis City and upstream of Ahvaz	Karoon-Zargan
4	Between Shooshtar City and Band e Mizan	Karoon-Band e Mizan	10	Ahvar Region	Karoon-Pol e Panjom
5	Between Shooshtar City and Pol e Koshtargah	Gargar-Pol e Koshtargah	11	Between downstream of Ahvaz and Darkhovain	Karoon-Om el Tommair
6	Between Band e Mizan and Band e Ghir	Shotait-Band e Ghir			

Table 4: The results of C-Mean clustering analysis based on the water quality for aquatic life

The number of classes	Class1	Class2	Class3	Class4	Class5	Class6	Class7
3	1-3-4-5	2-6-8-9-10-11	7	–	–	–	–
4	1	3-4-5	2-6-8-9-10-11	7	–	–	–
5	1	3-5	4	2-6-8-9-10-11	7	–	–
6	1	3-5	4	2-6-8-9-10	11	7	–
7	1	3-5	5	4	2-10	8-9-11	7

Table 5: The results of fuzzy clustering analysis based on the water quality for aquatic life

λ	The number of classes	Class1	Class2	Class3	Class4	Class5	Class6	Class7	Class8	Class9
2.9	1	1-2-3-4-5-6-7-8-9-10-11	–	–	–	–	–	–	–	–
3.5	2	1-2-3-4-5-6-8-9-10-11	7	–	–	–	–	–	–	–
6.5	3	1	2-3-4-5-6-8-9-10-11	7	–	–	–	–	–	–
10.5	4	1	3-4-5	2-6-8-9-10-11	7	–	–	–	–	–
12.5	5	1	3	4-5	2-6-8-9-10-11	7	–	–	–	–
20.5	6	1	3	4-5	2-10	6-8-9-11	7	–	–	–
30.8	7	1	3	4-5	8-6	2-10	9-11	7	–	–
35.9	8	1	3	5	4	8-6	10-2	9-11	7	–
72.8	9	1	3	5	4	8-6	10-2	9	11	7

Table 6: The results of fuzzy clustering analysis based on the water quality for drinking uses

λ	The number of classes	Class1	Class2	Class3	Class4	Class5	Class6	Class7	Class8	Class9
1.6	1	1-2-3-4-5-6-7-8-9-10-11	–	–	–	–	–	–	–	–
1.7	2	1-2-3-4-5-6-8-9-10-11	2	7	–	–	–	–	–	–
3.2	3	1-3	2-4-5-6-8-9-10-11	7	–	–	–	–	–	–
3.5	4	1-3	4-5	2-6-8-9-10-11	7	–	–	–	–	–
4.6	5	1-3	4-5	10-6	2-8-9-11	7	–	–	–	–
6.8	6	1-3	4-5	10-6	8-9-11	2	7	–	–	–
7.4	7	1-3	4-5	10-6	9-8	11	2	7	–	–
9.3	8	1	3	4-5	10-6	9-8	11	2	7	–
12.3	9	1	3	4-5	6	10	9-8	11	2	7

Table 7: The results of fuzzy clustering analysis based on the water quality for irrigation uses

λ	The number of classes	Class1	Class2	Class3	Class4	Class5	Class6	Class7	Class8
13	1	1-2-3-4-5-6-7-8-9-10-11	-	-	-	-	-	-	-
13.3	2	1-3-4-5	2-6-7-8-9-10-11	-	-	-	-	-	-
17.8	3	1-3	4-5	2-6-7-8-9-10-11	-	-	-	-	-
19.2	4	1-3	4-5	2-6-8-9-10-11	7	-	-	-	-
22.8	5	1-3	4-5	2-6-8-9-10	11	7	-	-	-
29.7	6	1-3	4	5	2-6-8-9-10	11	7	-	-
49.7	7	1	3	4	5	2-6-8-9-10	11	7	-
65.3	8	1	3	4	5	2-8	6-9-10	11	7

DISCUSSION

By comparing water quality data of the sampling points located in a class with the water quality standards, the developed clusters can be ranked. The results show that reach 7 (Gargar - Ban e Ghir) and the reach located between Darkhovain and Persian Gulf, which is affected by the backwater of the Persian Gulf, have a critical water quality condition. Comparing the results of c-mean crisp and fuzzy clustering methods (Tables 4 and 5) show that the clusters are somehow different. For example, when the river reaches are classified to three classes, fuzzy clustering method separates the reaches with the best (reach 1) and the worst (reach 7) water quality condition from the other reaches. However, in c-mean method, reaches 1, 3, 4 and 5 with partially different water quality are located in the same class. When the river reaches are classified to four classes, two models provide the same clusters (Tables 4 and 5). The fuzzy clustering method can provide better clusters comparing to the crisp relation method, when a river reach can not adequately be as-

signed to one cluster because it may be located between the clusters but the c-mean as an advanced crisp clustering, does not have such deficiency and can provide almost similar clusters. The main problem of the c-mean and the fuzzy methods is that their results are dependent on the selected distance criteria and similarity matrix, respectively.

The results of c-mean method are almost similar to the results of the fuzzy method. Fuzzy analysis is more efficient and natural than other methods of clustering or WQI methods in water quality zoning. In water quality assessment, especially when WQI score is close to the threshold between normal and abnormal condition, c-mean or fuzzy clustering methods can be applied as alternative tools.

The results show that the proposed models can be affectively used for water quality zoning in river systems and in ranking the reaches from the most critical to the least critical water quality condition considering different water quality variables.

ACKNOWLEDGEMENTS

The valuable contribution of the managers and engineers of Khuzestan Environmental Protection Agency for providing data and site maps as well as the technical assistance are hereby acknowledged.

REFERENCES

- Horton R K (1965). An index-number system for rating water quality. *Water Pollution Control Fed*, 37: 300-306.
- Kung H T, Ying L G, Liu Y C (1992). A complementary tool to water quality index: fuzzy clustering analysis. *Water Resources Bulletin*, 28: 525-33.
- Ott W R (1980). *Environmental Indices-Theory and Practice*. Ann Arbor Science Publishers, Inc., Ann Arbor, Michigan.
- Ross J T (1997). *Fuzzy Logic, with Engineering Applications*. McGraw-Hill Inc.
- Wang P (1983). *Theory of Fuzzy Sets and Its Application*. Shanghai Science and Technology Publishers, Shanghai, China.
- Zadeh L A (1965). Fuzzy sets. *Information and control*, 8: 338-53.
- Zadeh L A (1973). Outline of a new approach to the analysis of a new systems and design process. *IEEE Trans, SMC*, 3: 28-44.